

Oberteil Draufsicht
Top, real outside view

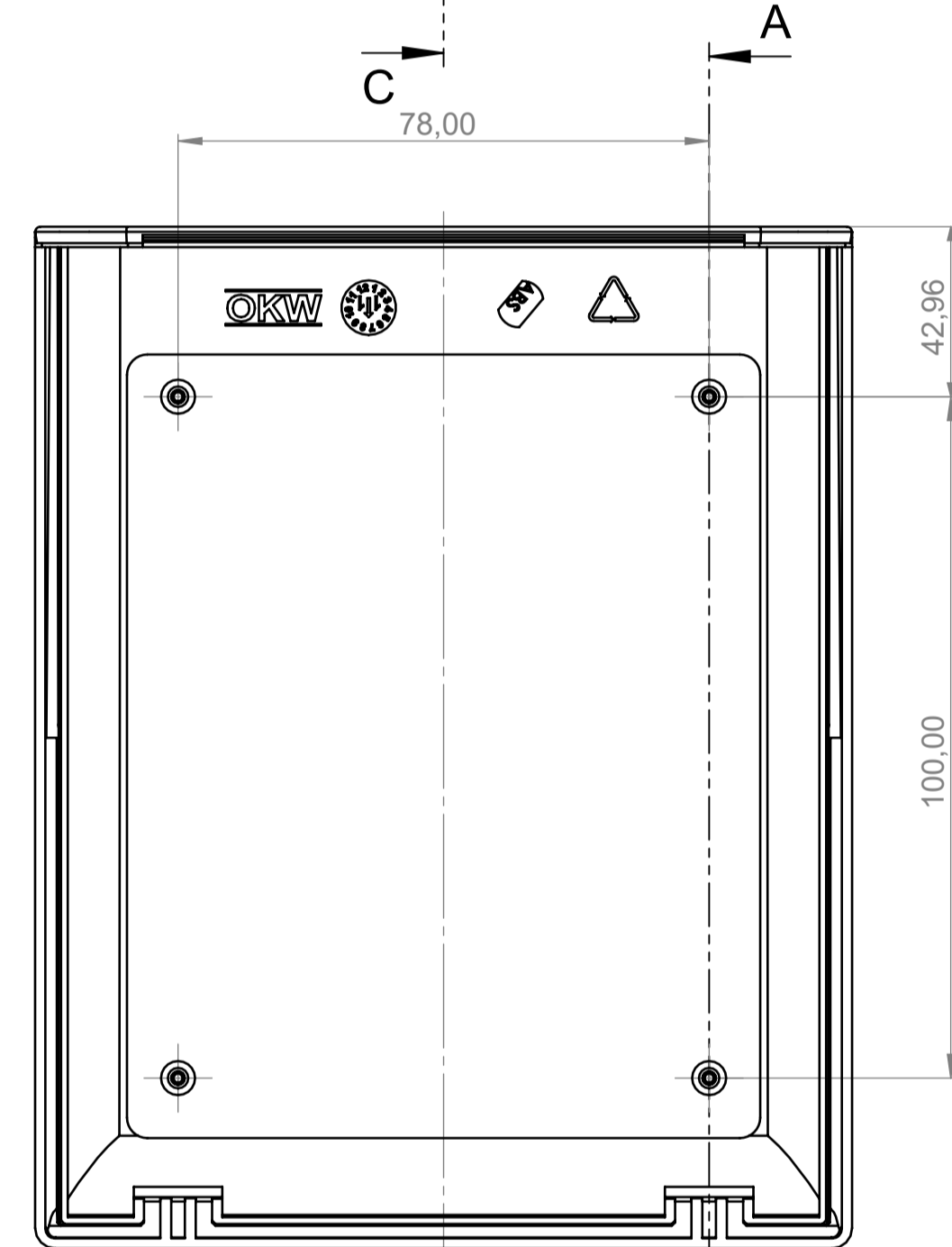

Oberteil Innenansicht
Top, real inside view

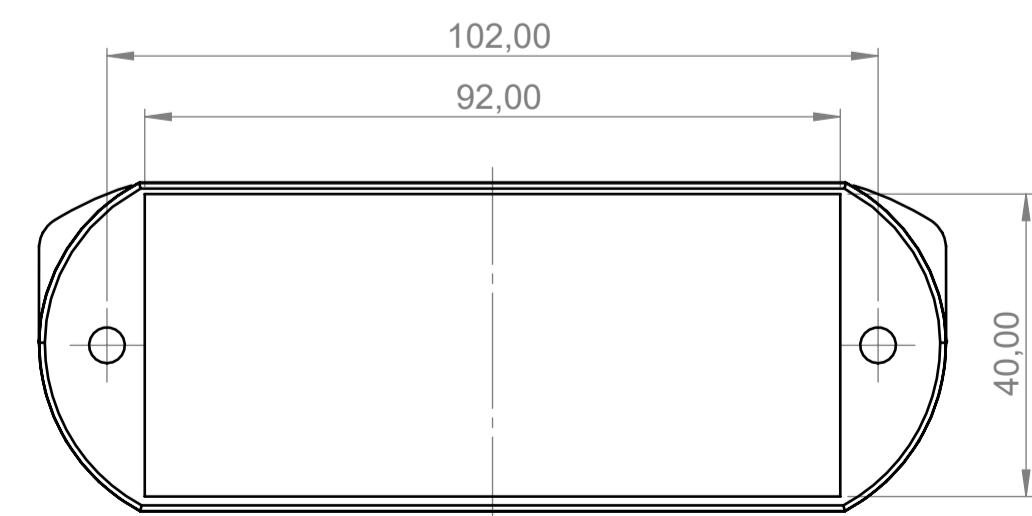

Oberteil- auf Flansch
Top, real view to rear

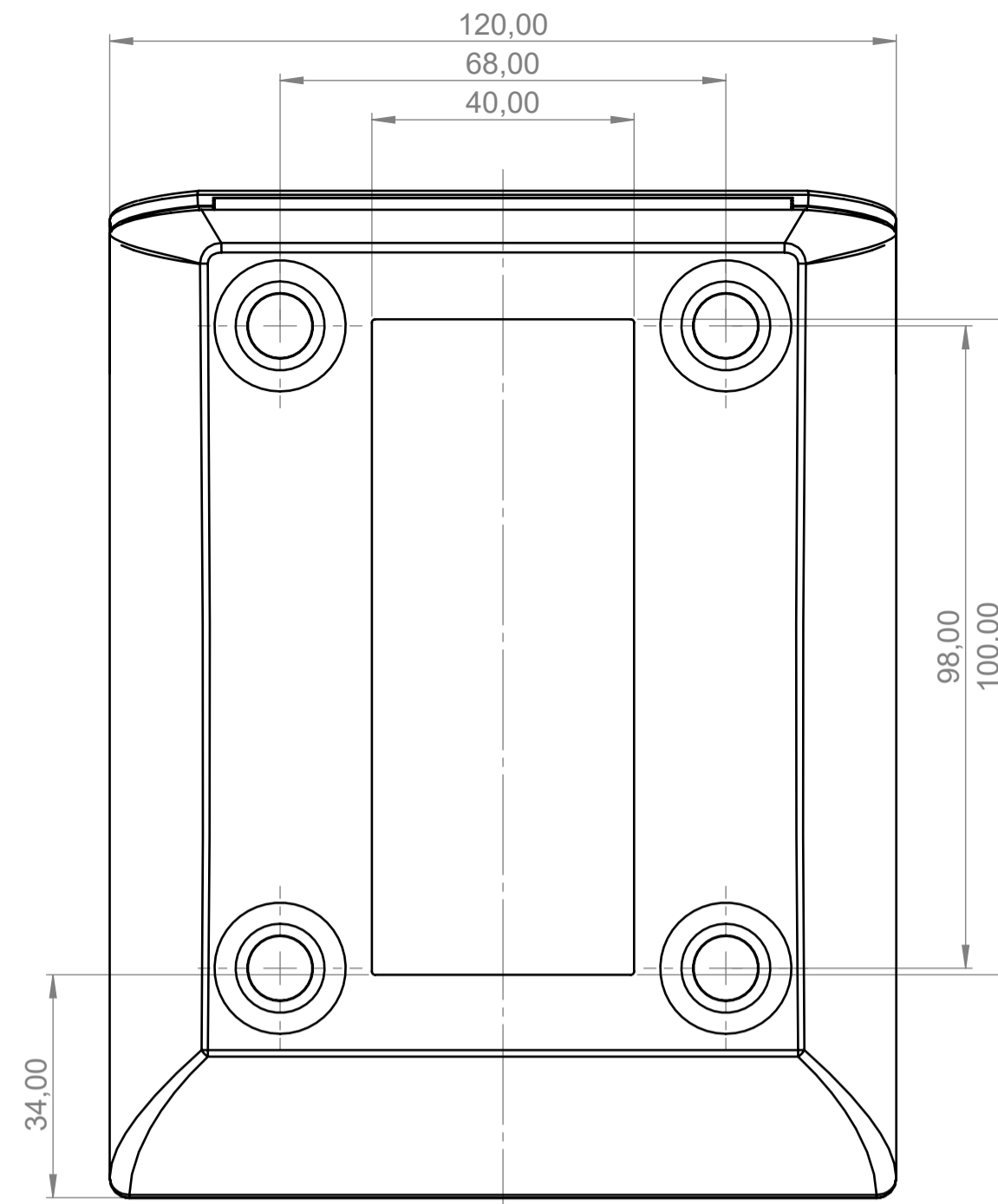

Unterteil Untersicht
Base, real outside view

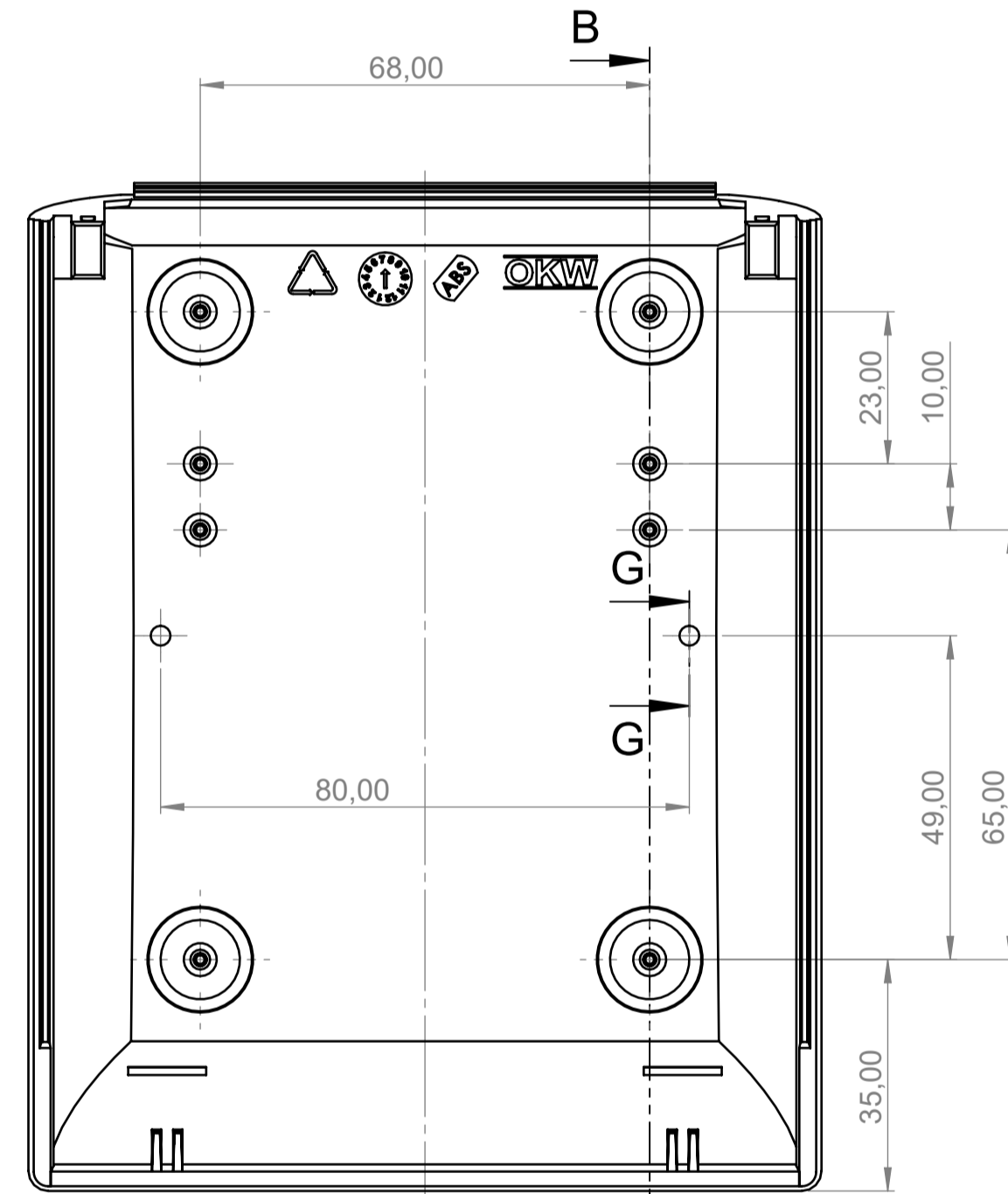

Unterteil Innenansicht
Base, real inside view

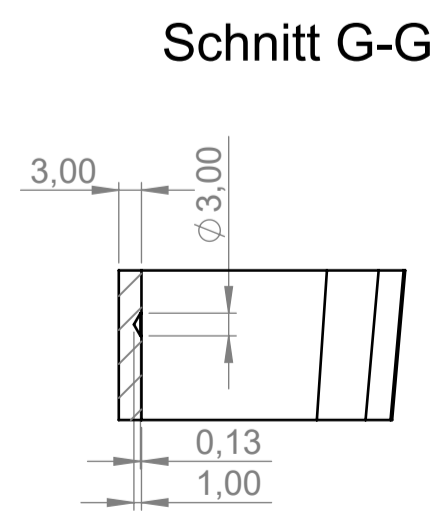

Schnitt G-G

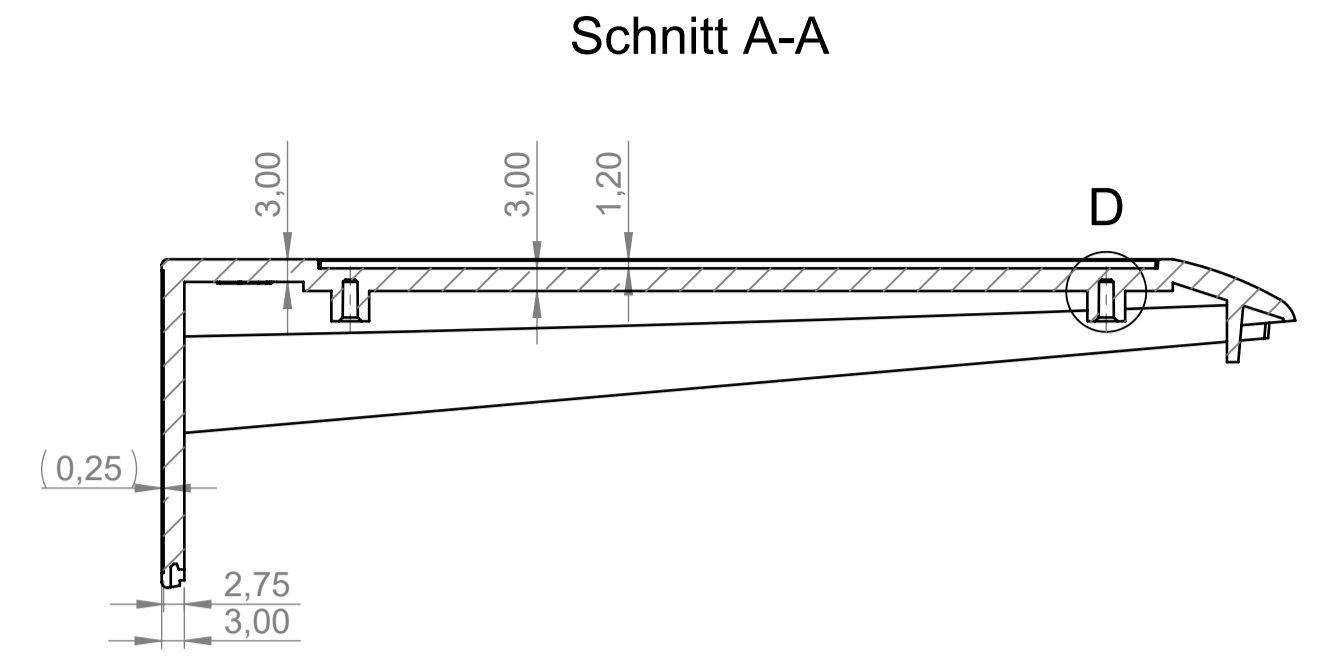

Schnitt A-A

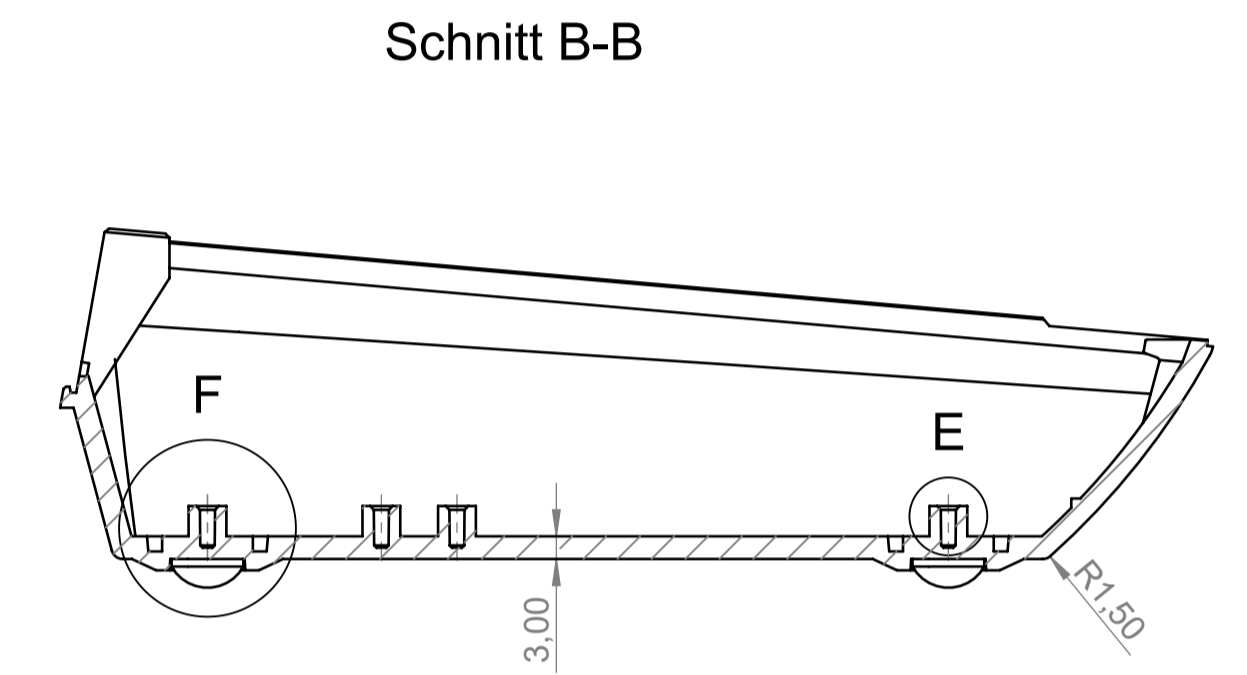

Schnitt B-B

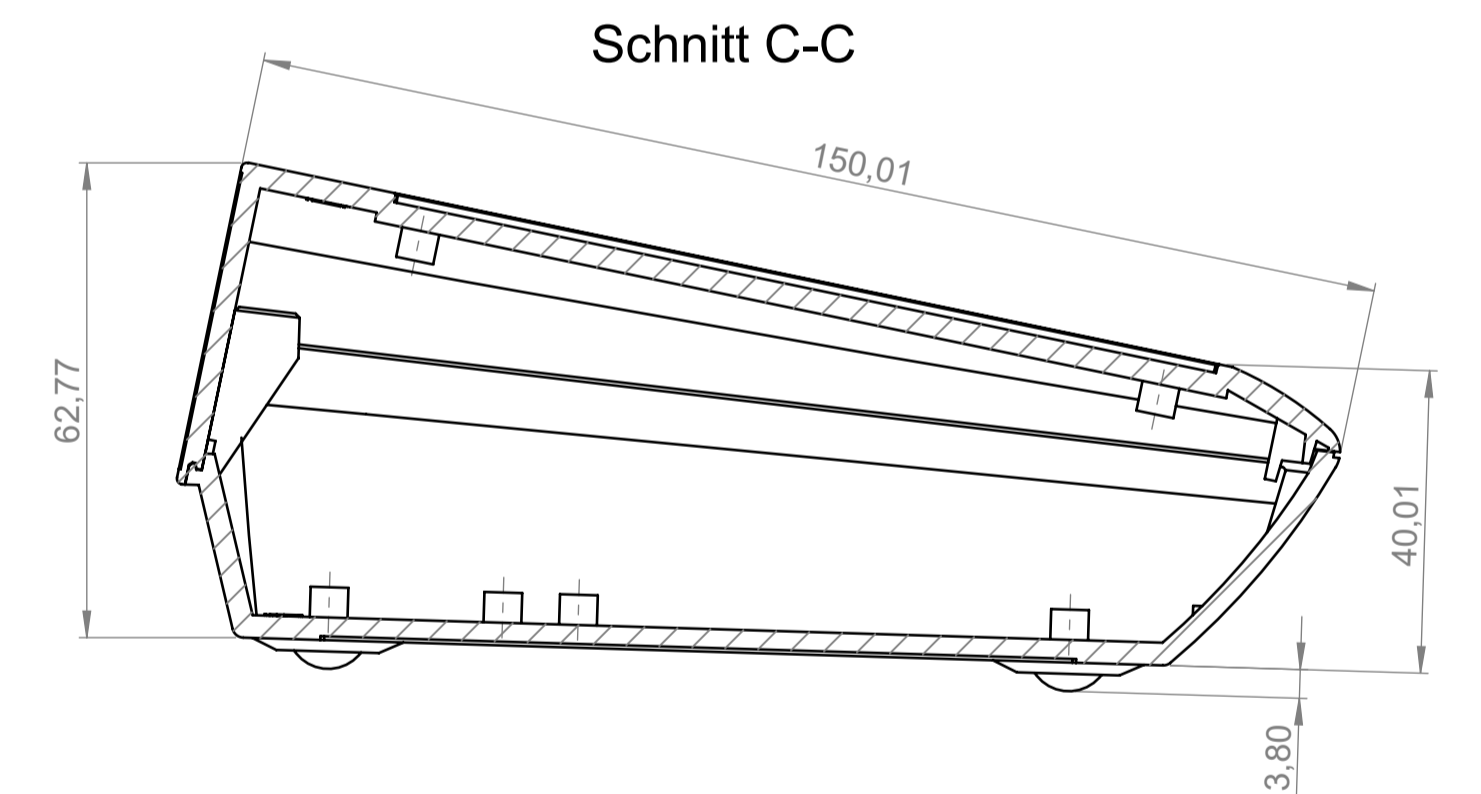

Schnitt C-C

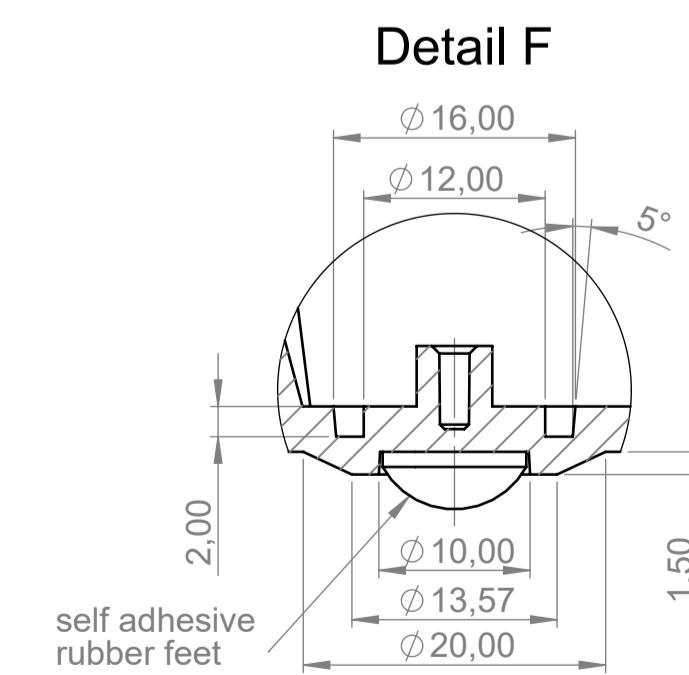

Detail F

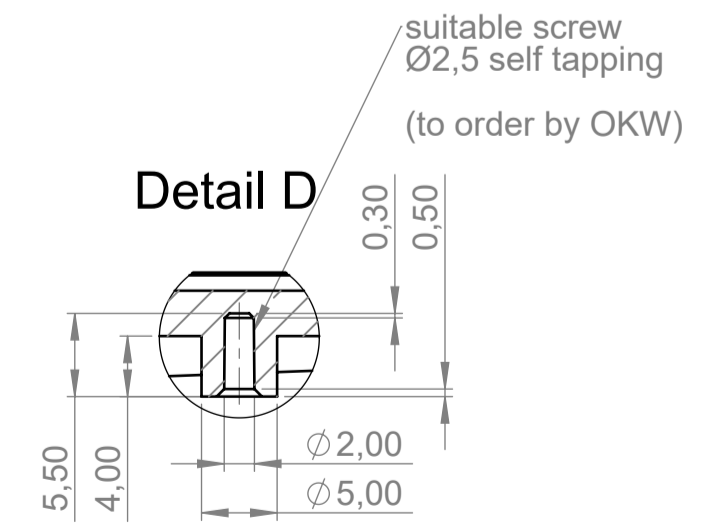

Detail D

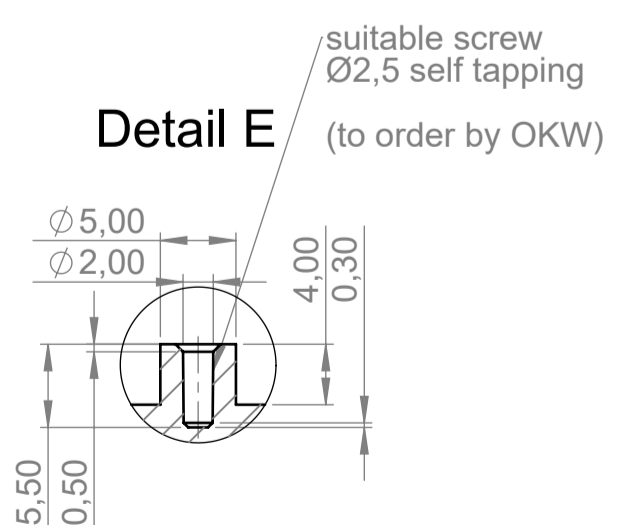

Detail E

<p>Bitte die Maße an aktuellen Teilen abnehmen. Diese unterliegen material- und produktionsspezifischen Fertigungstoleranzen.</p> <p>Please take the dimensions from current parts. These are subject to material and manufacturing-specific tolerances.</p>	<p>Informationskopie wird nicht aktualisiert. Copy for Information will not be updated.</p> <p>Technische Änderungen vorbehalten. Interner oder Druckfehler begründen keinen Anspruch auf Schadenersatz. Wichtige Einbaumaße bitte direkt mit dem aktuellen Produkt ablesen. Subject to technical modification without prior notice. Typographical and other errors do not justify any claim for damages. All dimensions should be verified using an actual moulded part. Sous réserve de modifications techniques. Toute erreur ou faute d'impression ne justifie aucune demande d'indemnisation. Veuillez priver les clients de vérifier les dimensions des composants avec les boliers avant le montage.</p>	<p>Erst. am: 10.02.2021 Erst. von: J. Farrenkopf Freig. am: 21.01.2022 Freig. von: J. Farrenkopf Revision: 01</p>	<p>Toleranzen: DIN 16901 T130 Volumen: Zeichnungsart: KUNDE</p>	<p>Status: SERIENFREIGABE DIN 6 Teil 2</p>
		<p>This document contains proprietary information of OKW Gehäusesysteme GmbH and is rendered subject to the conditions that the information be retained in confidence and not be reproduced or copied and not be used or incorporated in any product.</p>		<p>OKW GEHÄUSE SYSTEME</p>
			<p>M 1:1</p>	<p>Dateiname: 0000967</p>